

Temperature Detector in Bearing Shoe Case Style C and D, Potting Method

Suggested installation procedure

1. For 1/8" (3,20mm) detectors (case style C), drill a .128" (3,25mm) diameter hole (#30 drill) in the bearing shoe where temperature detection is desired.
2. For .080" (2,05mm) detectors (case style D), drill a .086" (2,20mm) diameter hole (#44 drill) in the bearing shoe where temperature detection is desired.
3. Apply a small amount of silicone heat sink compound to the tip end of the temperature detector (Dow Corning's #340 or similar compound is recommended). Apply enough compound to fill the drill tip cone at the bottom of the hole when the detector is installed. This compound will improve thermal conductivity from bearing shoe to detector when installed, and will result in faster response of the detector to bearing temperature change.
4. Insert the detector into the hole until it reaches the bottom.
5. Pot the leadwire in place where it enters the shoe: use an epoxy or other suitable potting compound compatible with the bearing shoe materials, temperature, and service conditions. During application and curing of the potting compound, make certain the detector remains at the bottom of the hole. Position the shoe so the leadwire extends upward. This method is recommended because it uses gravity to help keep the detector at the bottom of the hole.
6. When routing the leadwire from the bearing shoe, leave sufficient slack in the leadwire for movement of the shoe when it is in service. Use mechanical retainers to secure the leadwire externally to the shoe, or pot the leadwire in place using epoxy or other suitable potting compound.

NOTE: Although the illustrations on the following page depict a bearing shoe, the above installation procedure can be used with other types of bearings and also with equipment other than bearings.

DR: <u>OCT 12-08-93</u>	Minco CAGE IDENT. 09359	Engineering Instruction 184 ECO #43020, Rev D
CHK: <u>DLW 12-08-93</u>		
ENG: <u>DLW 12-08-93</u>		
APP: <u>DLW 04-20-05</u>		

1/8" DIA [3,20 mm] (CASE STYLE C)

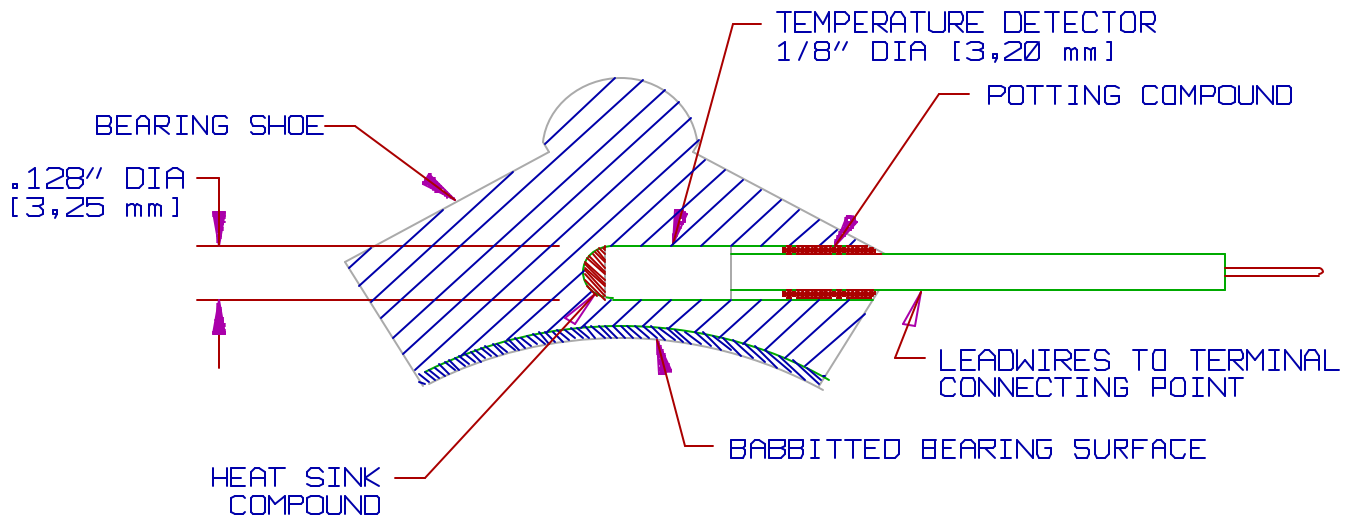

.080" DIA [2,05 mm] (CASE STYLE D)

